

# V

## A Family of Chemists

### The Life and Times of Alfred Springer 1854-1946

Alfred Springer (figure 1) was born in Cincinnati, OH, on 12 February 1854, the son of Lemuel Springer and Antoine Fries (1-6). Little is known of his father's family background (7). However, his maternal grandfather, Moritz Fries (figure 2), was born the son of a rabbi in Fuerth Germany in 1790 and, after service in the Napoleonic Wars, became a teacher of business studies and mathematics in Fuerth, as well as a prominent leader in the Jewish reform movement. Springer's mother, Antoine, was the third of eight children and the eldest of four daughters born to Moritz and his wife, Mariana Strum (8). All eight children would eventually immigrate to the United States, where they were finally joined by their father after the death of his wife in 1856. By the time of his own death in 1876, Moritz had become sufficiently prominent in the local re-



Figure 1. Daguerreotype of Alfred as a baby with his mother Antoine Fries, c. 1854.

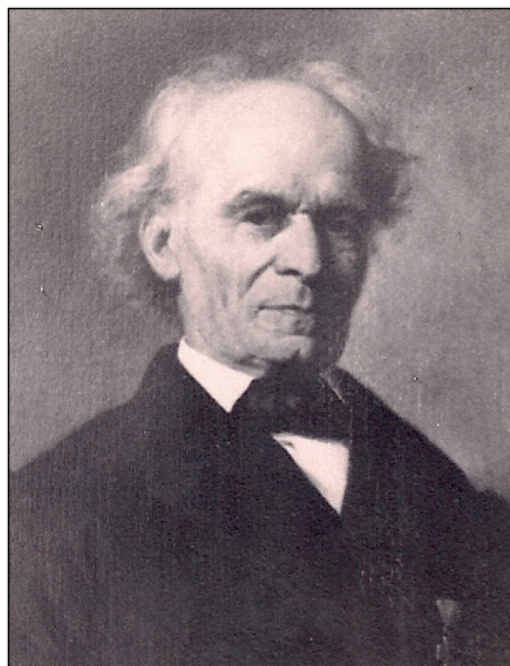

Figure 2. Oil painting of Springer's maternal grandfather, Moritz Fries (1790-1876), showing his military medal (the Bavarian Cross of Honor for Bravery) for his service in the Napoleonic Wars.

formed Jewish community of Cincinnati to merit an obituary by none other than the famed rabbi, Max Lilienthal (9).

It was three of Antoine's four brothers – Alexander, Karl (Charles), and Gustave – who would play a significant role in shaping her young son's future choice of career. The eldest, Alexander (figure 3), was trained in chemistry at the Universities of Erlangen and Paris. In 1843 he entered into the service of the King of Spain in connection with a project designed to survey and economically develop the Sierra Morenas region of the country, including a plan for its partial colonization by Germans under the auspices of an organization known as the German-Spanish Society (10). In recognition of his services, Alexander was knighted

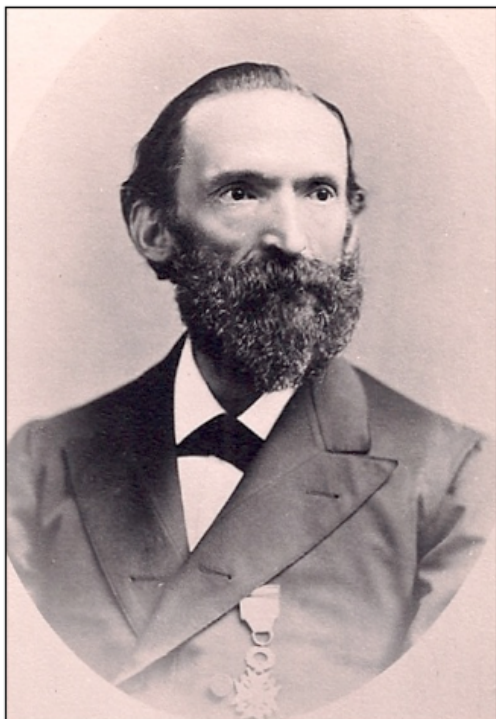

Figure 3. Springer's eldest maternal uncle, Alexander Fries (1821-1907), wearing the Order of Carlos the Third conferred upon him by the King of Spain.

by the King in 1852 and also awarded the coveted Order of Carlos the Third (11).

Feeling that the proposed colonization scheme in Spain was progressing too slowly, a restless Alexander joined his sister Antoine and her family in Cincinnati in 1855. Here, in partnership with his brother-in-law, Lemuel Springer, he constructed a small factory for the production of coal oil or Cannel oil made via the destructive distillation of Cannel coal, otherwise known as mineral wax or bituminous slate. After the untimely death of Lemuel, he was joined in this venture by his younger brothers, Charles and Gustave Fries, though the latter was a mere teenager at the time (12).

Having a high hydrogen content, Cannel oil burned with a virtually smokeless flame and was consequently highly prized as a fuel for oil lamps. However, the discovery of petroleum in Western Pennsylvania by Drake in 1859, and the subsequent rapid rise of kerosene as a cheap alternative fuel for oil lamps, soon made the Cannel oil business unprofitable. In response to this trend, Alexander reorganized the original factory and, under the new name of Alex Fries & Bros. Chemical Works, began dealing instead in by-products of the local Cincinnati soap and candle industries, such as paraffin,

glycerine, ethers, and organic fatty acids. Ultimately, however, the company would find its most dependable and profitable niche by specializing in the manufacture of flavoring agents for the food and beverage industries.

### Heidelberg and the Family Business

As a boy Alfred Springer (figure 4) appears to have been not only the apple of his young widowed mother's eye but a surrogate son to his uncle Alexander, who would remain a bachelor his entire life. In addition, he was also a precocious student, as indicated by the fact that he graduated from Hughes High School in Cincinnati in 1870 at the relatively young age of 16. Apparently his mother had retained her late husband's shares in the chemical works run by her brothers and it was determined that these would fall to her son once he came of age. With this in mind, he was sent abroad immediately after graduation to study chemistry at the University of Heidelberg under the guidance of the famous German chemist, Robert Bunsen, in order to obtain the necessary technical training for his future role in the family business. Here he once more proved to be precocious, as on 6 May 1872 he was awarded



Figure 4. Alfred as a young boy, c. 1866.



Figure 5. Alfred Springer as he appeared at age 18 as a young student at the University of Heidelberg, c. 1872.

his doctorate in chemistry at the tender age of 18 (figure 5) for work on hydroxylamine derivatives done



Figure 6. Wilhelm Lossen (1838-1906).

under the supervision of Wilhelm Lossen (figure 6) rather than Bunsen (5).

Among the surviving mementos of Springer's life is a copy of the telegram that he sent to his uncles back in Cincinnati upon the successful completion of his oral examinations two days earlier (figure 7) (13, 14):

*Heidelberg, 4 May 1872*

*To: Fries Brothers Chemists, Cincinnati*

*Raised [i.e. promoted] – a splendid examination*

*Dr. Alfred*

as well as a copy of the letter which his mother sent to him upon hearing the news, which began (15):

Blank No. 1.  
**THE WESTERN UNION TELEGRAPH COMPANY.**  
The rates of this Company require that all messages received for transmission, shall be written on the message blank of the Company, under and subject to the conditions printed hereon, which conditions have been agreed to by the holder of the following message.

ANSON STAGER, Gen'l Sup't, }  
 CHICAGO, ILL. }  
 WILLIAM ORTON, Pres't, }  
 C. H. PALMER, Sec'y, } New York.

Dated *Cable* *May 4<sup>th</sup>* 1872

Received at 56 & 58 West Third Street, Cincinnati. 640 *per*

To *Fries Brothers*  
*Chemists*  
*Cincinnati*  
*Raised a splendid examination*  
*Doctor Alfred*

Figure 7. Telegram of 4 May 1872 announcing Springer's successful completion of his oral examinations at Heidelberg.

*My magnificent boy,  
 My dear Doctor!*

*It is now twelve o'clock midnight; the happy excitement brought about by the telegram we received an hour ago won't allow me to sleep, and I find it best to get up and put my feelings into words. It probably will not be many words, because my heart is so tremendously full that, though everything is nicely collected there, nothing seems to come into my pen. Above all, let me give you my congratulations upon your new achievement, which no doubt cost you work, trouble, and worry enough.*

*Indeed, I now understand your latest letters, which were written in puzzles and which, to be honest*



Figure 8. Springer's youngest maternal uncle, Gustave Fries (1841-1914), as caricatured by Cincinnati cartoonist E. L. Bushnell in 1905. Unlike his brothers Alexander and Charles, Gustave apparently had no chemical training and presumably dealt instead with the sales and financial aspects of the business.

*with you, rather disturbed me. I was afraid that you had become ill as a result of your overly strenuous work schedule, and that you would end up with nothing for all your work but bad health. I see, thank heavens, that I was wrong, and that you – my eighteen year old child – have instead been crowned with the title of doctor. Surely I do not need to tell you that I wish you every happiness and blessing; you know, of course, that all of my hopes and desires are bound up in the happiness and future of my children. Dear grandpa is beside himself with joy and will no doubt be up early in the morning to bring the happy telegram to [your aunt] Julia and [uncle] Albert ...*

This accomplishment was also celebrated in a small clipping from a local Cincinnati newspaper which read (16):

*Alfred Springer of Cincinnati, nephew of the well-known chemist, Alexander Fries, went last year to Germany to study chemistry. After due examination he*

*was admitted to the University of Heidelberg, where, after one year's study, although but eighteen years old, he was promoted to a Doctor of Chemistry and Magister of Arts, something which, to our knowledge, has never occurred before. We congratulate the family and the young doctor.*

Returning to Cincinnati in 1873, the youthful Springer immediately assumed his position as a full partner with his uncle Alexander in the family's chemical business, then located at Nos. 312-316 East Second Street in downtown Cincinnati. His uncle Charles, who was also trained as a chemist, had moved to New York City in 1866 (17) and, after the death of Alexander in 1907 and that of his youngest uncle Gustave (figure 8) in 1914 (18, 19), Springer continued to run the company on his own until his retirement in 1931 at age 77.

### Family and Home

In 1879 – six years after returning to Cincinnati – Springer married Eda Elsas. The couple had two children: a son, Alfred Jr., and a daughter, Elsa. When of age, Alfred Jr. also followed family tradition, earning a doctorate in physical chemistry from Johns Hopkins in 1912 for work done under the direction of Harry Clary Jones, followed by employment in the family business, which he continued to run for several years after his father's retirement (20, 21). Elsa, on the other hand, married a German naval reserve officer by the name of Christian Meyer. With the outbreak of the First World War, Meyer was naturally called into active service and Elsa found herself and her oldest daughter trapped in Germany for the duration, her younger daughters having been left behind with her parents in Cincinnati. As might be expected, this situation proved



Figure 9. A winter view of Springer's Norwood mansion as it appeared in its prime.

quite stressful for Springer and his wife, and placed him, in the words of a friend, “in a cruel position” due to the flagrant anti-German feelings that were rampant during the war (6, 22). Interestingly, several of Elsa’s grandchildren and great-grandchildren would also become chemists.

The Springers initially resided at No. 387 West Fourth Street in downtown Cincinnati. In 1891, however, they moved to a larger home (figure 9) on Montgomery Road in the Cincinnati suburb of Norwood. Here, on an estate of 10½ acres, Springer, who was an avid arboriculturist and who would play an active role in the American Forestry movement, planted at “least two examples of every variety of scrub and tree indigenous to the Southern Ohio Valley” (5). Along with the well-known Cincinnati pharmacist, John Uri Lloyd, who at the time also resided in Norwood, Springer was instrumental in bringing natural gas, water, sewers and other public utilities to the area. After the death of his wife in 1937, Springer would live with Alfred Jr. and his wife in the Belvedere Apartments in Avondale until his own death nine years later.

### Inventions

Though Springer would never have a formal academic affiliation, he soon displayed a remarkably broad range of scientific, technical, and professional interests far in excess of those required to keep the family business afloat. This is not to say that the business itself did not require a certain level of chemical expertise – an expertise that was humorously commented upon by Springer’s close friend, Harvey Wiley, in 1923, during the heyday of prohibition (6):

*Alfred knows more about the essences, ethers, esters, aldehydes, and acids which are used by the rectifiers to make crooked whiskey than anybody else in the country except myself. His firm has always been manufacturers of complete outfits of artificials for the rectifier. I imagine he is now in cahoots with the bootleggers.*

Earlier in his career Wiley had been a chemist with the Department of Agriculture in Washington, DC, and had played a key role in framing the first Pure Food and Drug Act of 1906.

In addition to his purely chemical interests, whether of a commercial nature or extracurricular (of which more anon), Springer also developed an intense interest in mechanical inventions, and between 1877 and 1891 would be granted more than 22 patents, of which only his first (a method for chemically processing fat) (23) and his last (a process for producing alco-

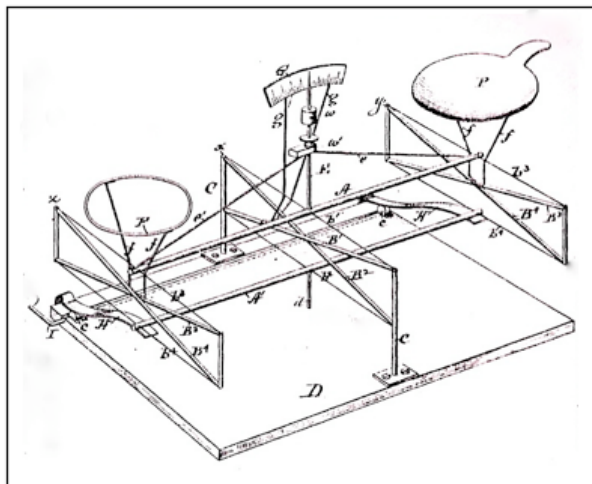

Figure 10. The 1882 patent drawing of the internal structure of the torsion balance showing the double beam and the three intersecting pivot frames with crossbar supports.

hol) dealt with chemistry (24). Six of the remaining patents dealt with grain meters and are of little interest in the present context (25), two dealt with musical instruments (26), and 12 with the design of torsion balances. It is these latter patents that are perhaps the most significant.

Traditional balances used agate wedges or so-called knife edges as the pivots for both the balance beam and the pans. By the early 19th century such balances were able to attain sensitivities of the order of a tenth of a milligram ( $10^{-4}$  grams). However, this great sensitivity also meant that these balances took an extraordinarily long time to come to equilibrium – a problem that would exercise the ingenuity of countless balance makers for the next 150 years. In contrast, in a torsion balance both the beam and pans pivot about either thin perpendicular wires or metal bands. Because their movement twists or torques the bands, it also automatically generates a restoring or damping force, thereby causing such balances to rapidly equilibrate.

The essential features of the Springer torsion balance are evident in the very first patent of 1882 (figure 10) which reveals that a double beam was used which was intersected, at right angles, by three rectangular “pivot frames,” one beneath each pan and one in the center (27). These, in turn, consisted of an outer frame of metal banding mounted on X-shaped supports, the top and bottom band segments of which were connected to the beams. In addition, a platform design was adopted for the balance pans which placed them above the upper beam rather than suspending them beneath, as in conventional analytical balances. This was done in order to locate the center of gravity above the metal bands and so increase their sensitivity to torqu-



Figure 11. An example of a Springer-Roeder torsion balance from the Oesper Collections. The three pivot frames with their X-supports and the two columns of weights on either side of the lower beam's pivot point are clearly visible through the all-glass case.

ing. One of the few additions not shown in the original patent was the application of this principle to the lower beam as well via the addition of two vertical columns of weights on either side of its pivot point. Though other minor improvements and alternative uses (figure 12) were subsequently patented over the next six years (28), these basic design features remained unchanged, as illustrated by the circa 1920 example shown in figure 11.

Springer was not the sole inventor of the torsion balance. Many of the patents were issued jointly in Springer's name and those of his collaborators, Frederick Roeder and William Kent. In 1882 the three of them organized "The United States Torsion Balance and Scale Company," with offices in both Cincinnati and New York City, and a factory in Jersey City, NJ. Springer served as the company's president and Kent as its secretary and general manager. Though the torsion balance had the advantage of rapid equilibration, the very features which made this possible also limited its sensitivity to the centigram range ( $10^{-2}$  gram). As a consequence, it was never widely adopted by chemical laboratories, though the company was highly successful in marketing the balance to pharmacists, and most surviving examples found in antique stores bear evidence of having once been the property of a local drug store. In addition to the patents themselves, Springer also reported on the balance at various scientific meetings (29, 30) and in 1891 was awarded the John Scott Legacy Premium and Medal by the Franklin Institute and the City of Philadelphia for his contributions to balance design (4).

Even more curious are Springer's two patents on

musical instruments, which advocated the use of aluminum to replace traditional wood sounding boards in pianos and other string instruments. As with his torsion balance, Springer reported on his aluminum sounding boards at various scientific meetings (31-33), and, to prove his point, had an entire violin made from aluminum, which he would play when lecturing on the subject, and which was recalled many years later by his close friend, the American chemist, Edward Hart (6):

*Springer had an aluminum violin, equal or superior to any Stradivarius, with which he proceeded to complete our musical discrimination.*

### Family Strains

The reason why Springer's uncle, Charles Fries, had relocated to New York City in 1866 was apparently to head a New York branch of Alex Fries & Bros. In keeping with family tradition, Charles' own son, Harold Harry Fries (figure 13), who had been born in Cincinnati shortly before the family's move to New York, was, in due course, also trained as a chemist. Graduating from the Columbia School of Mines in 1885, he pursued graduate work at the University of Berlin, from which he received a Ph.D. in 1887 for work done under August Hofmann on the derivatives of melamine (34). Originally employed, like his father, in the New York branch of Alex Fries & Bros., Harold soon created problems when, in 1892, he and his brother, Albert Fries, decided to found a competing company in

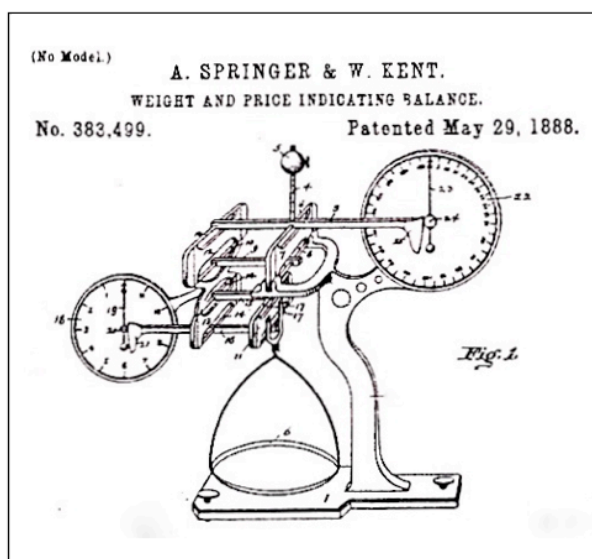

Figure 12. An 1888 patent drawing of one of many extensions of the original torsion balance developed by Springer and his associates, this one designed to automatically register both the weight and price of the product being sold.



Figure 13. Harold Harry Fries (1866-1946).

New York known as Fries Bros., Manufacturing Chemists (17).

Not only did the name of their new venture invite confusion with the original company, Harold and Albert continued to use many of the flavor formulations developed by Springer for the parent company, forcing Springer to eventually sue his cousins for copyright infringement. According to Springer's granddaughter, Elsa Miller, Springer was represented in the suit by the well-known Cincinnati lawyer and politician, Murray Seasongood. Though he won, the suit did not put his cousins out of business and in 1941 their company was incorporated under the modified name of Fries Bros. Inc., with Harold serving as President until his death in 1946 (35).

A somewhat similar confusion of family politics and business centered around Springer's patents on the torsion balance as sometime around 1902 both the patents and his interests in the Torsion Balance Company were somehow acquired by his cousin Harold, who became its sole President and Treasurer. The Cincinnati branch was discontinued and in 1915 the company acquired instead the firm of Christian Becker and Sons, which had been producing traditional knife-edge precision analytical balances since 1850 and which continued to operate under its original name as a subdivision of the parent company. That same year the Torsion Balance Company was also officially incorporated, with Harold once again acting as president until his death in 1946 (17).

According to Springer's granddaughter, these incidents hardly exhaust the list of Springer's apparent failings as a practical businessman. One favorite family story is that he was hired in the 1880s to standardize the syrup recipe for a newly marketed soft drink called Coca-Cola and was paid in company stock, which he sold after a few years for a pittance. Had he retained this stock instead, it would now be worth a fortune.

### Professional Activities

Throughout his career Springer was an enthusiastic joiner and supporter of scientific societies and reveled in the company of his scientific peers. In 1875 he joined the American Association for the Advancement of Science (AAAS), serving as its General Secretary in 1884 (figure 14) and as its Vice President in 1892. In 1884 he also helped to organize in Cincinnati the first national meeting of what eventually became the American Forestry Association, and in 1887 he became a corresponding member of the British Association for the Advancement of Science (BAAS).

In October of 1879 Springer invited local chemists to his home on 4th Street to discuss the possibility of organizing a local chemical society. This was officially formed in December of the next year as *The Cincinnati Chemical Society*, with a membership of 15,

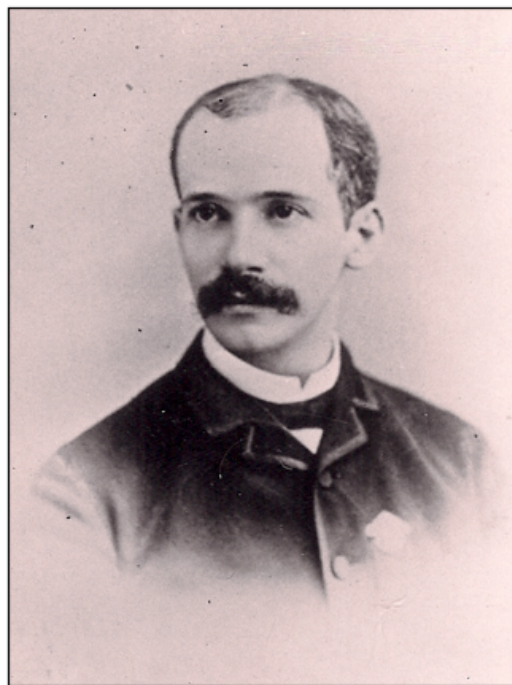

Figure 14. Springer as he appeared in 1884, the year he served as the general secretary for the American Association for the Advancement of Science.

**OHIO MECHANICS' INSTITUTE.**

---

**POPULAR LECTURES,**  
 UNDER THE AUSPICES OF THE  
**DEPARTMENT OF SCIENCE AND ARTS.**

The Fourth Lecture in the Popular Scientific Course of the Ohio Mechanics' Institute, will be delivered

**FRIDAY EVENING, JANUARY 25, 1884,**  
**By Dr. Alfred Springer, Ph. D.**  
 THE SUBJECT WILL BE

**THE CELL AND ITS FUNCTIONS.**

---

The Cell and Contents will be thoroughly discussed, with special reference to  
**PROTOPLASM AND CHLOROPHYL.**  
 The Lecturer will show that everything in living nature, from the lowest and most insignificant organism, to the highest type of creation, is composed of cells, and will illustrate this by means of stereopticon views.

The Lecture will be delivered in Greenwood Hall, at 8 o'clock P. M., and a large attendance is expected.

**ADMISSION, 25 CENTS.**

Figure 15. An 1884 poster announcing a public lecture by Springer as part of the Ohio Mechanics' Institute's public outreach program and illustrating Springer's growing interest in biochemistry.

including Springer, Roeder, John Uri Lloyd, and the University of Cincinnati's first Professor of Chemistry Frank Wigglesworth Clarke, who also served as the Society's President from 1880-1883 (36). The next year the Ohio Mechanics' Institute invited the Society to become the Chemical Section of its newly organized Department of Science and Arts. Besides publishing papers in its new journal, the *Scientific Proceedings of the Ohio Mechanics' Institute*, members of the Chemical Section also gave popular scientific lectures for the general public (figure 15). However, the new journal collapsed in 1884 after only seven issues and by 1887 the Chemical Society had become inactive as well. It was revived once again in 1890 by Clarke's successor at the University of Cincinnati, Thomas Herbert Norton, with Springer as President, and was merged with the American Chemical Society two years later as the Cincinnati Section of the ACS (37).

In a biographical account written in 1937 Springer claimed that, during his first 20 years of membership in the Cincinnati Chemical Society and in the local section of the American Chemical Society, he had (4):

... contributed an average of more than one paper per year covering the results of his researches or reviews of literature on a wide range of subjects, including fermentation, distillery slops, coffee, milk, water purification, illuminating gas, aluminum sounding boards, etc.

However, very few of these lectures were apparently converted into published papers. A computer search of ACS publications revealed only one published paper by Springer in all of the Society's various journals (38). Likewise, there is no listing for Springer in Pogendorff and the *Royal Society Catalogue of Scientific Papers* lists only nine titles under his name, over half of which are actually abstracts or brief mentions of oral papers delivered at various scientific meetings (39). Four additional titles are listed in a 1912 biographical account without, however, any clues as to where they were published (3, 40).

As suggested by the poster in figure 15, by the 1880s Springer had become increasingly interested in the study of fermentation and bacteriology. According to his granddaughter, he also became a fervent admirer of the work of Louis Pasteur, who, though initially trained as a chemist like Springer, had experienced a similar shift in interest. Springer's speciality in this field was the study of nitrifying micro-organisms found in the soil (41, 42), a subject which he made the focus of his Vice Presidential Address before Section C of the AAAS in 1892 (43). Indeed, the 1912 biographical account claimed that he was the first to discover "denitrifying ferments among the micro-organisms of the soil which form a link between plants and their nitrogenous constituents" (3). However, I have found no mention of Springer's work in standard accounts of this subject.

### Return to Heidelberg

Although most of Springer's time as a student at Heidelberg had been spent in intense study, he had also found time for social activities, including taking fencing lessons from the then German champion and the formation of friendships with other students, including one with Charles Darwin's youngest son, Horace (1851-1928), who in 1887 extended an invitation to Springer to attend the Victoria Golden Jubilee Meeting of the British Association for the Advancement of Science in Manchester. Springer accepted the invitation and that summer he and his family boarded a boat for England. While there, Springer had the opportunity to talk on his torsion balance and to meet, among others, both Lothar Meyer and Mendeleev. He also made arrangements for a side trip to the continent to visit his old professors at Heidelberg. To his great sadness,





Figure 16. Portrait of an aged Robert Wilhelm Bunsen (1811-1899) acquired by Springer during his visit to Heidelberg in 1887 and currently in the Oesper Collections.

however, he found that his former Professor of Physics, Gustav Kirchhoff, was terminally ill (he would die that October) and that the great Bunsen was also in poor shape, as recounted in a letter written by Springer on 12 August 1887 (44):

*Here I am, after an interval of more than fifteen years, writing a letter in lovely old Heidelberg. All of us are as much charmed with the dear old place as I was in former years.*

*... Yesterday morning I went to Bunsen's private house and, after ringing the bell for five minutes, the servant girl opened the door and I asked for "Excellency." The girl told me he was quite sick but she would take my card up. She did so and came back with the answer that "Excellency" would be very much pleased to see me. So I went up to his room and to my sorrow found Bunsen very much aged and reduced in flesh. He was very cordial, made me sit on the sofa next to him, told me that he had an indistinct recollection of me and then, like any other common mortal, began to complain of his ills ... Besides the servant girl, who*

*was downstairs, the old man hasn't a soul in the building to take care of him.*

*He asked me a thousand and one questions about myself, doings and family. I told him about the torsion scale and said I would bring him one to look at the next day. He said he would be pleased to see it provided he was not too weak. After spending an hour and a half with him, I came back to the hotel. Eda and Lilly then went with me to a florist and had the finest basket of flowers made up that we could obtain in Heidelberg and I sent them to him with my card.*

*This morning I took my scale with me and called again. When I went upstairs he almost shook my hand off thanking me for my attention. I then showed him my scale. I never yet have seen anybody so delighted with it as he was. He did not know what to admire most – the ingenuity of the construction, the principle, or the wonderful machinery work on the same, including the handsome appearance. But what seemed to delight him the most was that one of his old students should be the co-inventor of the instrument. He asked me whether I would lend it to him for a day or so so that he could examine it at his leisure. I then told him I had brought it along from America with the intention of offering it to him as a slight token of respect. He at first thought it was too much to accept, but afterwards he took it and said he would have it set up in his private room under a glass case.*

*I spent the whole morning with him, then bid him goodbye, perhaps forever. If his disease lasts much longer, it will ruin all hopes for recovery [But, of course, Bunsen would live for yet another decade]. It is a great misfortune that such men ever grow old, for today he is still the wonderful scholar and the kind-hearted teacher that I loved and respected of yore.*

Before leaving that day, Springer had a private conversation with the servant girl about Bunsen's care and possible needs. According to Springer's granddaughter, the girl told him that Bunsen could no longer afford the morning sweet rolls that he dearly loved to have with his breakfast. As a result, Springer set up a tab, to be billed to him in the United States on a yearly basis, with the local baker to anonymously supply Bunsen with his morning treat for the remaining years of his life. Alas, I have no information on what became of the "Springer sweet roll endowment" after Bunsen's death.

### The Great Milk Debate

A typical example of Springer's innate scientific curiosity in action and his willingness to apply it in the public interest has been preserved for us by Harry

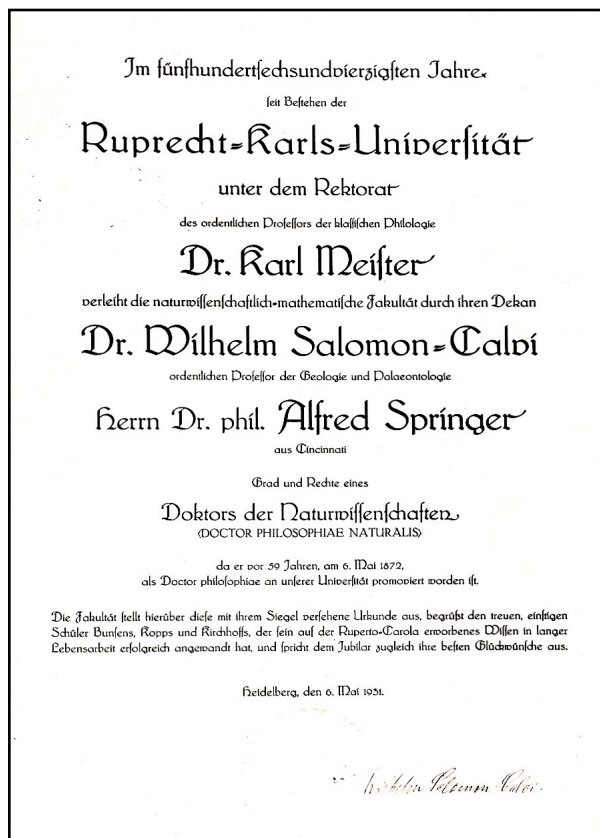

Figure 17. Springer's honorary doctorate from the University of Heidelberg.

Shibley Fry (5). In 1908 Fry called to Springer's attention the curious case of a bottle of French Brothers Certified Milk that had stood, unrefrigerated, on the outside window sill of Fry's laboratory at the University for two weeks without going sour. Aware that even pasteurized milk normally contained lactic acid bacteria, Springer was immediately drawn to the mystery of the nonsouring milk.

His first action was to purchase several bottles of the milk in question and to confirm Fry's initial observation. In light of his knowledge of bacteriology, its failure to sour could only mean that the milk contained an antibacterial chemical preservative of some sort, yet the Cincinnati Academy of Medicine had certified that the milk was free of all foreign chemicals and preservatives. When news of these results reached the French Brothers Dairy and the Academy of Medicine, the latter called for a joint meeting of the Academy and the Cincinnati Section of the American Chemical Society to clarify the situation. This took place on 15 April 1908 in the old Ohio Mechanics' Institute building on the corner of 6th Street and Vine (5):

*The large assembly hall was crowded. Various papers*

*were read by both chemists and doctors. The meeting ended, however, in a never-to-be-forgotten verbal row between the doctors and chemists because Dr. Springer tenaciously maintained that the certified milk undeniably contained a preservative which prevented souring and putrescence and he pledged himself to find it.*

Unable to detect the usual suspects, such as formaldehyde, Springer finally resorted to evaporating the milk to dryness and extracting its mineral content using sulfuric acid. When he added potassium hexacyanoferrate(II) to the resulting solution, he obtained the characteristic reddish-brown color of copper hexacyanoferrate(II), also known as Hatchett's Brown – a definitive test for copper. This he further verified by electrolytically depositing copper from the solution. Subsequent investigations at the French Brothers Dairy found that they were adding copper sulfate to their boiler water as an anti-algal agent and that infinitesimal quantities were being mechanically transferred in the generated steam used to sterilize the milk bottles. So in the end, Springer was able to absolve both the French Brothers Dairy and the Cincinnati Academy of Medicine of any charges of willful adulteration and to confirm the extreme effectiveness of copper salts as antibacterial agents – results which he summarized in a paper published the following year in the *Journal of Industrial and Engineering Chemistry* (38).

### Honorary Doctorate

In 1931 Springer was informed by the University of Heidelberg that, on the occasion of its 546th anniversary, it was awarding him an honorary doctorate of natural science (figure 17) in recognition of the fact that he was one of its oldest surviving graduates. This event was celebrated in November of that year at the University of Cincinnati with a formal dinner jointly sponsored by the local section of the American Chemical Society and the Cincinnati Germanic Society. Held in the new YMCA Building on Calhoun Street, it was followed by a presentation ceremony in the auditorium of the Teacher's College and attended by President Hicks of the University. Also included on the program was a lecture by Springer entitled "A Sketch of Some Chemical Trends," in which he contrasted the state of chemistry in 1931 with that prevailing during his student days at Heidelberg nearly 60 years earlier (45).

Nor was this event the last hurrah for Springer. Six years later, in the summer of 1937, he once again sailed for Europe at the age of 83, this time in response to a special invitation to attend the Annual Meeting of the British Association for the Advancement of Science

in Nottingham and to visit his great grandchildren, who were then living in Italy (46). In the fall of 1930 Springer and John Uri Lloyd had served as the honorary chairs when the 80th National Meeting of the American Chemical Society convened in Cincinnati (47) and in the spring of 1940 Springer, at age 86, was once again asked to serve as honorary chair for the the 99th National Meeting in Cincinnati (48).

Photographs of Springer taken well into his 90s (figure 18) show that he retained the appearance and vitality of a 60-year old almost to the end. His grandson, Alfred Springer III, told me that this was true until only a few months before his death at age 92 on 24 February 1946, when, almost overnight, he seemed to suddenly age, both physically and mentally, as though the intervening years of seemingly suspended aging had suddenly caught up with him.

### Evaluation

Local newspaper coverage of Springer's death in 1946 carried the headline "Death Ends Brilliant Career of Noted Chemist" and press coverage of earlier events in his life often used similar phrases, such as "noted savant," "prominent chemist and inventor," etc. (49). Has the passage of time justified such assessments or are they to be dismissed as mere newspaper hyperbole? As with the case of John Uri Lloyd, many of the later honors bestowed upon Springer seem to have had as much to do with his longevity as with his objective merits as a scientist and inventor, and to the extent that several of these honors were actively initiated by Harry Shipley Fry of the University of Cincinnati Chemistry Department, there is also the question of whether both Lloyd and Springer – as well-to-do local businessmen – were being consciously cultivated as potential financial donors to the department.

However, despite these nagging doubts, I think one can make a strong case for the claim that Springer's career was sufficiently distinguished to set him apart from the countless industrial chemists who have lived and died in total obscurity, though it was hardly of such significance as to have won him a permanent place in the history of science proper. His purely chemical publications, though interesting, were neither voluminous nor groundbreaking. On the other hand, his role as the co-inventor of the torsion balance probably does entitle him to a place, albeit minor, in the history of chemical instrumentation.

Much harder to appreciate in this age, when scientific significance is measured only in terms of national and international prominence, is Springer's role, for more than 70 years, as an important intellectual and cultural force in the local Cincinnati scientific commu-

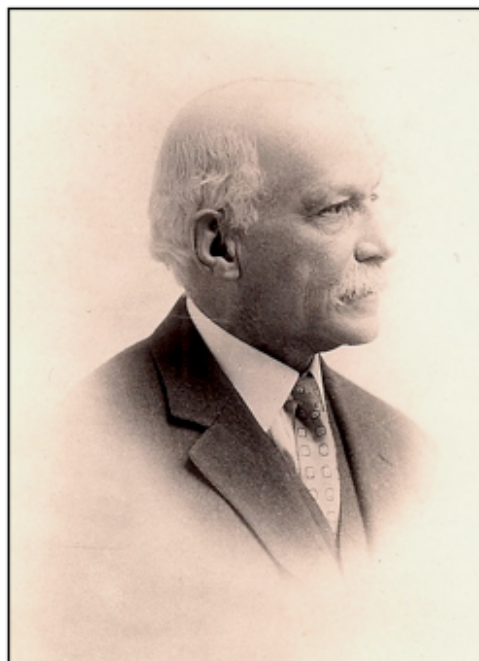

Figure 18. Springer in old age.

nity – a role which was of great importance in an era when such local organizations still sponsored the cultivation and presentation of original scientific work based on local talent rather than functioning as mere social extensions of national societies and being relegated instead to sponsoring monthly dinners, a dependency on outside guest speakers, and the doling out of local awards.

### Acknowledgements

I would like to thank Springer's grandchildren, Alfred Springer III and Mrs. Elsa Miller, for their generous donations of copies of family documents and photographs which have made this paper possible and offer my apologies for the inexcusably long delay in finally making proper use of their bequest.

### Reference and Notes

1. "Alfred Springer," in *Marquis Who Was Who in America, 1607-1984*, Marquis: Providence, RI., 1984.
2. "Alfred Springer in J. M. Cattell, Ed., *American Men of Science*, Science Press: New York, NY, 1906, p. 303.
3. "Alfred Springer," in C. F. Goss, *Cincinnati – The Queen City*, Vol. 3, Clarke: Cincinnati, OH, 1912, p. 335.
4. Anon., "This Month We Honor Dr. Alfred Springer," *Cincinnati Engineer & Scientist*, **1937** (April), 11.
5. H. S. Fry, "Alfred Springer, Feb. 12, 1854 - Feb. 24, 1946," *CINTACS Newsletter*, **1990**, 27(2), 6-9. A printing

of the Springer Memorial Address given before the Cincinnati Section of the ACS in 1946. Original manuscript in the Oesper Collections.

6. E. Hart, "American Contemporaries: Alfred Springer," *Ind. Eng. Chem.*, **1923**, *15*(8), 863.

7. Springer is a very common name among 18th- and 19th-century German immigrants. I have been unable to establish any connection between Lemuel Springer and the 19th-century Cincinnati philanthropist, Reuben Springer, after whom both Springer Hall and Springer School are named. Nor is there any connection with the Cincinnati TV personality, Jerry Springer, who was actually born in Great Britain.

8. Entries in the Fries family Bible. Copy in the Oesper Collections.

9. M. Lilienthal, "The Late Moritz Fries," Unidentified newspaper obituary dated 5 January 1876. Copy in the Oesper Collections.

10. *Prospectus for the Sociedad Espanola Alemana*, 1851. Copy in the Oesper Collections.

11. "Cincinnati Knighted by King is Dead," and "Death Hand Laid on Notable Norwood People in Past Week, Chemist Alexander Fries One." Unidentified newspaper obituaries dated 1907. Copies in the Oesper Collections.

12. Untitled and unidentified newspaper clipping reporting on the celebration of Alexander Fries' 80th birthday in 1901. Copy in the Oesper Collections.

13. Western Union Telegram of 04 May 1872 from Alfred Springer, Heidelberg, to Fries Brothers Chemists, Cincinnati, OH. Copy in the Oesper Collections.

14. No thesis is listed for Springer in P. R. Jones, *Bibliographie der Dissertation amerikanischer und britischer Chemiker an deutschen Universitäten, 1840-1914*, Deutschen Museums: München, 1983. Jones also reported to me that a subsequent search by the archivist at Heidelberg failed to locate any record of Springer's doctorate.

15. Letter of 04 May 1872 from Antonie (née Fries) Springer, Cincinnati, OH to Alfred Springer, Heidelberg. Copy in the Oesper Collections.

16. Untitled and unidentified newspaper clipping reporting on Springer's graduation in 1872. Copy in the Oesper Collections.

17. "Harold Harry Fries, *National Cyclopaedia of American Biography*, Vol. 33, White: Clifton, NJ, 1947, p. 219. Harold Fries was the son of Charles and a first cousin of Alfred Springer. This entry, however, incorrectly identifies Alexander Fries as Harold's grandfather, rather than as his uncle, which is impossible since Alexander remained a bachelor his entire life.

18. C. F. Goss, "Gustave R. Fries" in *Cincinnati – The Queen City*, Vol. 3, Clarke: Cincinnati, 1912, pp. 846-847.

19. E. A. Bushnell, "Gus Fries," in *Cincinnati As We See'em*, Newspaper Cartoonist Association of Cincinnati: Cincinnati, OH, 1905, p. 154.

20. A. Springer Jr., *A Study of the Conductivity and*

*Dissociation of Certain Organic Acids in Aqueous Solution at Different Temperatures*, Ph.D. Thesis, Johns Hopkins University: Baltimore, MD, 1912.

21. Unhappily, in 1958 Alfred Jr. and his wife ended their lives in a mutual suicide pact by taking cyanide. Curiously Alfred's Ph.D. advisor, Harry Clary Jones, had done the same back in 1916. See "Death Sealed with Cyanide," *Cincinnati Enquirer*, 30 August 1958. Copy in the Oesper Collections.

22. See, for example, the letter of 31 August 1914 from the American Consul in Hamburg to Springer reporting that his daughter and grandchild were safe and that his son-in-law had been called into service. Copy in the Oesper Collections.

23. A. Springer, United States Patent No. 187327, "Fat Treatment," 1877.

24. A. Springer, United States Patent No. 457799, "Process for Producing Alcohol," 1891.

25. United States Patents Nos., 365107, 365874, 365875, 365876, 365877, 365878, "Grain Meter," 1887 and Patent No. 394665, "Automatic Grain Indicator," 1888.

26. A. Springer, United States Patent No. 444770 "Sound Board for Musical Instruments," 1891; Patent No. 451863, "Violin," 1891.

27. F. A. Roeder, A. Springer, United States Patent No. 262905, "Beam Scale," 15 August 1882.

28. F. A. Roeder, A. Springer, United States Patent No. 262906, "Platform Scale," 15 August 1882; F. A. Roeder, H. F. Reum, A. Springer, United States Patent No. 262907, "Torsional Pivot-Scale Bearings," 15 August 1882; A. Springer, R. A. Roeder, United States Patent No. 310471, "Balance," 06 January 1885; A. Springer, United States Patent No. 310542, "Balance," 06 January 1885; A. Springer, United States Patent No. 310545, "Balance," 06 January 1885; A. Springer, R. A. Roeder, United States Patent No. 339946, "Torsional Pivot-Balance," 13 April 1886; A. Springer, R. A. Roeder, United States Patent No. 339947, "Torsional Balance," 13 April 1886; A. Springer, United States Patent No. 340010, "Molecular Pivot-Balance," 13 April 1886; A. Springer, United States Patent No. 340011, "Molecular Pivot-Balance," 13 April 1886; A. Springer, United States Patent No. 340012, "Molecular Pivot-Balance," 13 April 1886; A. Springer, United States Patent No. 340013, "Torsion Pivot-Balance," 13 April 1886; A. Springer, W. Kent, United States Patent No. 383499, "Weight and Price Indicating Balance," 29 May 1888.

29. A. Springer, "The Torsion Balances," *Trans. Amer. Inst. Mining Eng.*, **1884**, *12*, 569-573.

30. A. Springer, "Torsion Balances," *BAAS Report*, **1887**, 636.

31. A. Springer, "A Latent Characteristic of Aluminum," *Proc. Amer. Assoc. Adv. Sci.*, **1891**, *40*, 182.

32. A. Springer, "Aluminum Violins," *Nature*, **1894**, *50*, 485.

33. A. Springer, "Increase of Segmental Vibration in Aluminum Violins," *BAAS Report*, **1897**, 564.
34. H. H. Fries, *Beitrag zur Kenntnis des Melamins und seiner Derivate*, Ph.D. Thesis, University of Berlin, 1887.
35. W. Haynes, *American Chemical Industry*, Vol. 6, Van Nostrand: New York, NY, 1945, pp. 171-172.
36. The constitution, membership list, and meeting notes for The Cincinnati Chemical Society of 1880 are located in the University of Cincinnati Archives.
37. For further background on the Cincinnati Chemical Society of 1880 and its relation to the Ohio Mechanics' Institute, see W. B. Jensen, "Robert Bowne Warder, 1848-1905," in *Cincinnati Chemists: Assorted Papers on the History of the Cincinnati Chemical Community*, Oesper Collections: Cincinnati, OH 2012, pp. 22-29.
38. A. Springer, "Anti-Putrescent Effects of Copper," *J. Ind. Eng. Chem.*, **1909**, *1*, 676-678.
39. See references 29-33, 41-43 and A. Springer, "On Glycocholic Ether," *Am. Chem. J.*, **1879**, *1*, 181-183.
40. Other titles include "Pentachloroamyl Formate" (1881), "Dynamic Equilibrium in Poises Swinging in Opposite Arcs" (1882), "High Center of Gravity to Overcome Torsional Resistance" (1882), and "The Absence of High Upper Partials in Aluminum (1890).
41. A. Springer, "Reduction of Nitrate by Ferments," *Am. Chem. J.*, **1882**, *4*, 452-453.
42. A. Springer, "Fermentation without Combined Nitrogen," *Proc. Amer. Assoc. Adv. Sci.*, **1884**, *33*, 172-174.
43. A. Springer, "The Micro-organisms of the Soil," *Proc. Amer. Assoc. Adv. Sci.*, **1892**, *41*, 93-103.
44. Letter of 12 August 1887 from Alfred Springer, Heidelberg, to family in Cincinnati, OH. Copy in the Oesper Collections.
45. "Noted Chemist is Honored." Unidentified newspaper clipping dated November 1931. Copy in the Oesper Collections.
46. "Science and Great Grandchildren Lure Noted Savant to Visit Europe," *Ohio Times Star*, 23 June, 1937.
47. W. B. Jensen, "Remembering the 1930 Cincinnati Meeting of the American Chemical Society." in *Cincinnati Chemists: Assorted Papers on the History of the Cincinnati Chemical Community*, Oesper Collections: Cincinnati, OH 2012, pp. 168-172.
48. "Dr. Alfred Springer Honorary Chairman of Meeting," Unidentified and undated newspaper clipping. Copy in the Oesper Collections. See also "Preliminary Program for the Cincinnati Meeting of the American Chemical Society, 8-12 April, 1940," *Chem. Eng. News*, **1940**, *18(1)*, 15-16.
49. "Death Ends Brilliant Career of Alfred Springer, Chemist," *Cincinnati Enquirer*, 26 February 1946.